

MSI-3460 Challenger 3

DIGITAL CRANE SCALE



Add Safety and Precision to Your Overhead Weighing

Using setpoints, the MSI-3460 can be programmed to change display color as weight limits are approached for greater operator safety.



The bright LED display makes it easy to read weights in all display colors.

Long range viewing is enhanced with a 1.5 inch (38 mm) ultra-bright LED digital display. Resolution settings of up to 10,000 divisions provide precise 0.1% loading accuracy over a range of capacities from 250 to 15,000 pounds. Operating time is extended to over 80 hours with a single 6-volt rechargeable battery.

The Challenger packaging has been upgraded to NEMA Type 4 / IP65 levels. Manufactured in the USA in strict compliance with the highest safety standards, Challenger continues to sustain minimum 200% safe and 500% ultimate overload ratings.

A ScaleCore electronics retrofit kit is available for upgrading existing MSI-3260 or MSI-3360 Challengers to the MSI-3460.

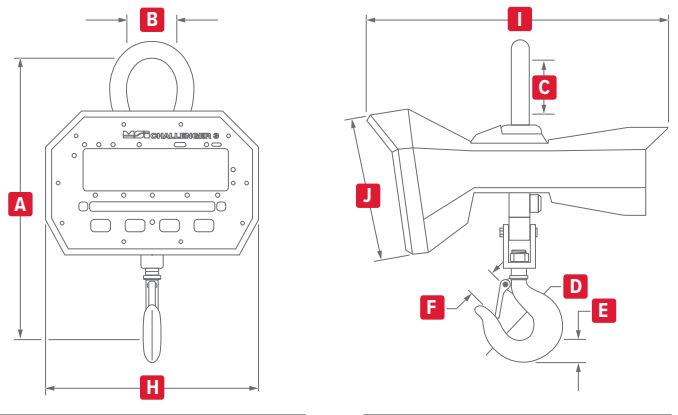

FRONT VIEW

SIDE VIEW

Capacity	Resolution	A	B	C	D	E	F	H	I	J	EST SHIP WT
250 lb / 125 kg	0.1lb / 0.05 kg	11.94 in 303 mm	2.0 in 51 mm	2.45 in 62 mm	1.63 in 41 mm	1.14 in 29 mm	1.16 in 29 mm	9.0 in 228 mm	12.7 in 332 mm	6.0 in 152 mm	22 lb 10 kg
500 lb / 250 kg	0.2 lb / 0.1 kg										
1,000 lb / 500 kg	0.5 lb / 0.2 kg										
2,000 lb / 1,000 kg	1.0 lb / 0.5 kg	16.67 in 423 mm	2.45 in 62 mm	3.40 in 86 mm	2.5 in 64 mm	1.81 in 46 mm	1.61 in 41 mm	9.0 in 228 mm	12.7 in 332 mm	6.0 in 152 mm	39 lb 18 kg
5,000 lb / 2,500 kg	2.0 lb / 1.0 kg										
10,000 lb / 5,000 kg	5.0 lb / 2.0 kg										
15,000 lb / 7,500 kg*	5.0 lb / 2.0 kg	21.65 in 550 mm	3.25 in 83 mm	4.28 in 109 mm	3.00 in 76 mm	2.26 in 57 mm	2.08 in 53 mm	9.0 in 228 mm	12.7 in 332 mm	6.0 in 152 mm	67 lb 30 kg

For higher capacity weighing and heavy-duty use, MSI recommends models MSI-4260, MSI-4300, MSI-6260CS or MSI-9300. Consult factory for higher capacities.

Note: 15,000lb (7,500kg) unit comes standard with 12ton top shackle. Crosby is a registered trademark of The Crosby Group, LLC.

*15,000 lb (7,500 kg) is NOT NTEP approved.

10 T



MSI-8004HD
LED Remote Display



MSI-8000HD LCD
RF Remote Display



MSI-8000
RF Remote Display



LaserLight 2
RF Remote Display



RF Rugged
Remote

COMPATIBLE WITH



MSI-3460 Challenger 3

DIGITAL CRANE SCALE



Create a complete crane scale system by pairing the MSI-3460 with the MSI-8000 RF remote display.

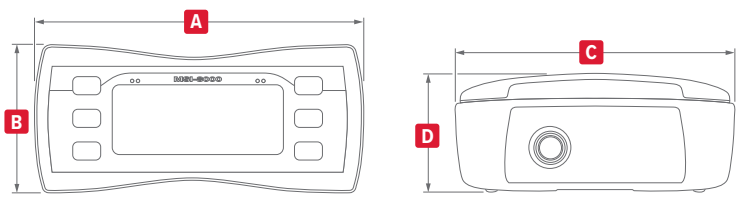

FRONT VIEW

SIDE VIEW

A	B	C	D	WEIGHT
8.0 in	3.85 in	3.85 in	1.37 in	0.98 lb
203 mm	98 mm	98 mm	35 mm	445 g

MSI-3460 SPECIFICATIONS

ACCURACY:	± 0.1% (+1 d) of applied load
RESOLUTION:	2,500 d max standard (up to 10,000 d max non-standard)
ENCLOSURE:	NEMA 4, IP65, powder coated cast aluminum
LIFTING EYE & HOOK:	Crosby® or equivalent with 360° non-bearing swivel hook
DESIGN OVERLOAD:	200% safe / 500% ultimate
FUNCTIONS:	Power: Turns unit ON or OFF Zero: Zeros applied load up to 100% of capacity (limited range in NTEP Certified/OIML configurations) Tare: Tares applied load and displays weight in net mode User: Programmable as TEST, UNITS, NET/GROSS, TOTAL and PEAK HOLD
DISPLAY:	Five-digit, 1.5 in (38 mm) LED with programmable brightness control; toggle between red, orange and green digits
DISPLAYABLE UNITS:	Pound or kilogram selectable
ANNUNCIATORS:	CO2, net, gross, total, peak, low battery, lb/kg, motion, setpoints, ACK IN, ACK OUT, RF
POWER:	6 volt rechargeable battery. 115/230 VAC battery charger is included
OPERATING TIME:	Up to 80 hours between charging with typical use. Less with optional RF model link
OPERATING TEMPERATURE:	Legal: 14° F to 104° F (-10° C to 40° C) Industrial: -10° F to 104° F (-40° C to 40° C)
AUTO-OFF MODE:	Select for 15, 30, 45, 60 minutes or off
AUTO SLEEP MODE:	Power down during non-use and power up with weight change or any key press
SERVICE COUNTERS:	Counts number of lifts over percentage of capacity and lifts over capacity
CALIBRATION:	Digital
FILTERING:	OFF, LO, HI-1, HI-2 selectable

MSI-3460 OPTIONS (Contact MSI for application consultation)

- RF modem install for connectivity to MSI-8000, MSI-8000HD RF, MSI-8004HD RF remote display, TranSend and LaserLight2 remote display (Typical range 100-300 ft line of sight)
- Rugged remote control (control for Off, Zero, Tare and other functions)(Requires 3460RF version, typical range 50 ft line of sight)
- Universal direct power supply (115/230 VAC)
- Audible alarm
- Wi-Fi communication is available for specialty applications

MSI-3460 APPROVALS



MSI-8000 RF REMOTE DISPLAY SPECIFICATIONS

FUNCTIONS:	On/off, zero, tare, peak hold, units, total, high resolution, net/gross, print, test
DISPLAY:	Six-digit, 1.0 in (26.4 mm) LCD
POWER:	Rechargeable lithium polymer battery; 24 hours operating time between charging in typical use 115/230 VAC battery charger is included
RF FREQUENCY:	2.4 GHz - 802.15.4 operating range 100 ft (30 m) typical
ENCLOSURE:	Industrial grade NEMA 4/IP65
OUTPUT:	Serial RS-232

SALES AND TECHNICAL ASSISTANCE

RICE LAKE
WEIGHING SYSTEMS

Dillon/Quality Plus, Inc. 214 E. Kansas St. Ste 101 Liberty, MO. 64068 Ph# 816-453-7600 Toll Free: 800-493-2263 www.dqplus.com