

MSI Tension Link

AND

MSI Clamp-on Load Cell



RICE LAKE[®]
WEIGHING SYSTEMS

MSI TENSION LINK AND MSI CLAMP-ON LOAD CELL

Integrated Load Sensors for Safe Crane Loads

Rice Lake Weighing Systems' Measurement Systems International (MSI) brand offers the MSI Tension Link and MSI Clamp-on Load Cell to enhance integrated solutions for crane rigging, clevis and attachment overhead weighing applications.

Easily integrated with pre-existing systems, the MSI Tension Link and MSI Clamp-on Load Cell are ideal for operations currently using cranes, as well as crane manufacturers and original equipment distributors in the crane and overhead material handling industry.

MSI Tension Link

The MSI Tension Link integrates between a crane block and lifting equipment to provide force measurement for lifted items, making it an ideal integration for cranes. The MSI Tension Link was designed for permanent installations and features a mil-spec connector and analog communications sensor to interface with weight transmitters and readout instrumentation, including the MSI-8004HD weight indicator, Rice Lake's SCT signal conditioning transmitters or MSI's TranSend® wireless load cell interface.

For current crane operators, the MSI Tension Link can be installed in lift chains or between the lifting apparatus and crane block to measure weight, as well as provide a safety indicator for overload and other conditions. The MSI Tension Link features a 7:1 safety factor for compliance with industrial and military safety requirements.

MSI Clamp-on Load Cell

The MSI Clamp-on Load Cell is a durable solution for measuring wire rope tension, providing dependable overload detection and prevention for overhead cranes and hoists.

Available in two envelopes to accommodate most common wire ropes, 3/8-1/2 inch and 9/16-3/4 inch, the MSI Clamp-on installs quickly and easily to the wire rope dead end. The integral signal cable can be connected to a variety of detection device such as the MSI-8004 LED indicator or an advanced SCT weight transmitter. Weight-based setpoints can be used to communicate with crane electronics providing operator alerts and safety shut offs based on unsafe load conditions.

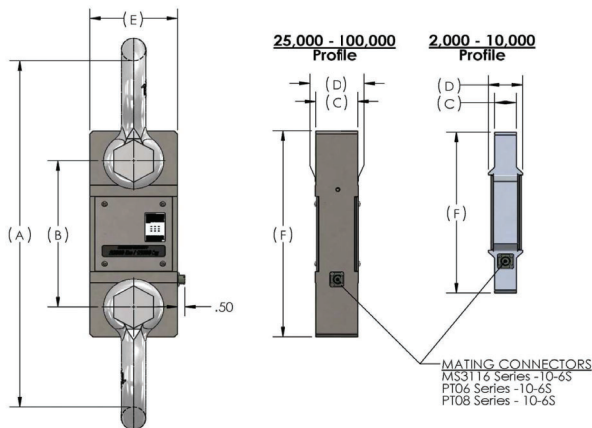

MSI Tension Link Dimensions

Capacity (lbs)	A	B	C	D	E	F	G
2,000	13.50	8.00	0.99	2.13	4.50	9.75	0.78
5,000	13.50	8.00	0.99	2.13	4.50	9.75	0.78
10,000	16.13	8.50	1.35	2.13	5.37	10.75	1.05
25,000	22.39	9.26	2.24	2.24	4.80	12.76	1.67
50,000	25.74	9.76	2.74	2.81	5.43	13.76	2.05
100,000	28.49	10.74	3.09	3.09	6.86	15.74	2.30

Your Rice Lake Weighing Systems distributor is:



MSI Tension Link Specifications

Accuracy:	0.1% of rated capacity
Bridge:	Input Resistance: 1,500 ohms Output Resistance: 2,000 ohms
Full Scale Output:	0.8mV/V
Material:	4340
Connector	
Pin Out:	A: EX+ B: Sig + C: Sig - D: EX-

MSI Tension Link Models

PN	Capacity (lb)
181907	2,000 lb
181908	5,000 lb
181909	10,000 lb
178093	25,000 lb
178094	50,000 lb
181910	100,000 lb

MSI Clamp-on Load Cell Specifications

Accuracy:	3-5%
Material:	ETD 150
IP Rating:	IP68
Cable Length:	20 ft. (6 m.) integral cable with blunt end termination
Cable Color	
Code:	Red + Excitation Black - Excitation Green + Signal White - Signal

MSI Clamp-on Models

PN	Wire Rope Size (inches)
179080	3/8-1/2 in
179082	9/16-3/4 in
Consult	3/4-1 in

MSI Clamp-on Dimensions

Cable O Range (in)	A	B	C
3/8 - 1/2 in	Cable O + 1.70	6.00	2.00
9/16-3/4 in	Cable O + 1.67	6.00	2.00

